



Warmth from the heart of J.A. ROBY inc.

OWNER'S MANUAL ULTIMATE



WOOD STOVE



Certified and tested
according to UL-1482-00
and ULC-S627-00 norms.

Revised August 20, 2009

490, rue de l'Argon
Québec (Québec) G2N 2C9
Phone: 418-849-8095 Fax : 418-849-0077
www.jaroby.com

ULTIMATE CONTENTS

WARNING.....	3
NOTICE.....	5
CREOSOTE.....	5
ULTIMATE - CHARACTERISTICS.....	6
INSTALLATION.....	7
VERTICAL INSTALLATION INSIDE A MASONRY CHIMNEY	8
EXTERIOR VERTICAL INSTALLATION	8
VERTICAL INSTALLATION ON A CATHEDRAL ROOF	9
CROSS INSTALLATION	10
VERTICAL INSTALLATION.....	10
CLEARANCES.....	11
FLOOR PROTECTOR	12
LIGHTING.....	13
FANS AND THERMODISC.....	14
PREVENTIVE MEASURES AND MAINTENANCE.....	15
REPLACEMENT PARTS LIST	16
INSTALLATION OF THE FIREBRICKS.....	17
FIGURE 1 . 0	18
LIMITED LIFE WARRANTY.....	20

READ CAREFULLY THIS MANUAL AND KEEP IT FOR FURTHER REFERENCES.

INSTALLATION OF THIS APPLIANCE MUST BE DONE BY A QUALIFIED AND CERTIFIED TECHNICIAN AND IN CONFORMITY WITH THE OWNER'S MANUAL GUIDE PROVIDED WITH THIS APPLIANCE. THE INSTALLATION MUST BE IN ACCORDANCE WITH LOCAL AND NATIONAL APPLICABLE REGULATIONS AND THE APPLICABLE BUILDING CODE .

Warning! Never modify this appliance!

WARNING

Before installing, please take a few minutes to read this handbook. Keep it in a sure place and easily reachable for future references. If this appliance is not properly installed, it could cause fire damages to the property, injuries and death. To reduce fire hazards, follow instructions contained in this handbook.

Contact an official inspector (ex: a fireman) or your insurance company for installation permit. Always respect the provincial and municipal building codes of your region.

Do not connect this appliance to a chimney that already serves for another wood stove.

The existing chimney should be inspected before any installation. In doubt, consult a specialist.

Never use a non-isolated exterior conduct or a single pipe as an exterior exit.

Minimum clearances found in this manual must be observed.

Install all firebricks before lighting the stove (if it is not already done).

Never use a non-isolated exterior duct or a pipe to evacuate chimney smoke.

Do not install in a mobile house.

Keep all combustible material (clothing, furniture, wood, matches, plastic, etc) at a distance of at least 91.5 cm (3 feet) from the appliance.

Do not use chemicals or fluids to light the fire. Never burn flammable waste or fluids such as gasoline, naphtha or engine oil.

This appliance is approved to burn wood. Do not use any other combustible.

Wood should not be stocked within the recommended minimums clearances or in the necessary space for the loading and the ashes evacuation.

Do not burn wet or freshly cut wood. Do not use construction debris such as pieces of 2x4 or plywood.

If the appliance starts to glow red, over firing is happening. Do not add fuel. Immediately close the doors and the air intake of the appliance until everything becomes normal again.

Do not charge the appliance beyond the firebricks height.

Ashes must be evacuated frequently, remove it with a small steel shovel.

Very hot when lighted. Keep the children away. Can cause burns by contact.

Considering the need of air for the combustion, a window or a door must be half opened sometimes (fresh air drainage) to balance the pressure in the house, especially if:

- A fan already evacuates air towards outside (kitchen, bathroom.)
- You want to avoid a repression of smoke when lighting the appliance and when reloading the wood.

It is recommended to have a smoke detector near the appliance.

You should contact your municipal or provincial fire department to have knowledge of the procedure to be followed in case of a chimney fire. Think of an emergency plan.

In case of a chimney fire:

- Hermetically close the doors and the air intakes.
- Water the combustible material adjacent to the chimney.
- Ring the alarm, evacuate the house if necessary and call the firemen.
- Never touch the pipes until the fire is not completely extinct.
- Do not use the chimney until it has been inspected or repaired.

Keep all the doors closed while the appliance is in function. Frequently verify the ceramics cords, they must always be in good condition.

The chimney pipe should not pass close to water, gas or oil pipes, nor close to electric wire or other types of conduits, of combustible materials in the roofs, the attics, the walls or the floors. If you have to make it pass through a wall or a part of combustible construction, do not forget that the installation must be in accordance with the CAN/CSA-B365. Use at least 12 feet of a 6 inches diameter vertical chimney.

NOTE:

FOLLOW THESE INSTRUCTIONS IN ORDER TO AVOID FIRE HAZARDS, WOUNDS AND PROPERTY DAMAGES.

NOTICE

The *Ultimate* was conceived to safely function the doors closed and only when burning firewood. Any change, modification or unauthorized installation will automatically cancel the certification of the appliance, its guarantee, its homologation and the appliance might become dangerous.

During the first hours of operation of your appliance, you must gradually heat it without exceeding 300°F (145°C), in order to let the paint cook slowly and to facilitate its adhesion with metal. It is normal that a light smoke is released from the paint during the first hours of use.

Even if this nuisance is temporary, open the windows and the doors in order to ensure good ventilation. This special paint is conceived to tolerate temperatures until 1200°F (650°C).

CREOSOTE

The wood burning slowly produces tar and other organic steams, which forms a whole called “creosote”. The steam condenses in the cool chimney when the wood is burning slowly. In this way, creosote residues are formed on the walls. Creosote can take several forms: tarry liquid, soot dust or deposits in crystal form. When in fire, the creosote releases a very strong heat and can be the cause of a chimney fire.

- **Do not knock on the glasses or violently close the doors.**
- **Do not use the appliance when a glass is broken or damaged.**
- **Do not build the fire too close of the glasses.**
- **Keep the doors closed when using the appliance.**
- **Do not connect the *Ultimate* with a chimney or a flue serving another heating appliance**

ULTIMATE - CHARACTERISTICS

Combustible	Wood
Recommended surface	500 à 3600 ft ² (46,5 à 334,45 m ²)
Evacuation pipe diameter	6 in (15,24 cm)
Chimney minimal height	12 ft (3,66m)
Dimensions	
Exterior height	33,5 in (85,1 cm)
Exterior width	27,5 in (70,0 cm)
Exterior depth	37 in (94 cm)
Door opening	16 X 10,5 in (41,0 X 27,0 cm)
Interior height	13,5 in (34,3 cm)
Interior width	20,5 in (52,1 cm)
Interior depth	25,25 in (64,1 cm)
Maximal length of log	25 in (64 cm)
Combustion duration	6 to 12 hours
Weight	460 pounds (208 kg)
Clearances	
Back	10 in (25,4 cm)
Lateral	20 in (50,8 cm)
Floor to Ceiling	84 in (213,4 cm)

INSTALLATION

A good installation is extremely important for a safe and efficient use of your J.A. Roby Inc. appliance. If you doubt on the way to install the appliance correctly, seek for professional installation service. We suggest you to call masters fitters.

1. Withdraw firebricks placed inside the appliance in order to reduce the weight and to facilitate the installation.
2. You must install a fireproof protector under the appliance, which must exceed of 18 inches to the front and of 8 inches on each side.
3. The free space shall not be reduced except under the approval of the authorities responsible for the application of the building code.
4. Install the chimney and an insulated wall thimble for an installation passing through a wall according to the instructions from the chimney manufacturer.
5. Install the firebricks in accordance with the recommended instructions for your model.
6. The appliance should not be connected to an hot air conduct

VERTICAL INSTALLATION INSIDE A MASONRY CHIMNEY

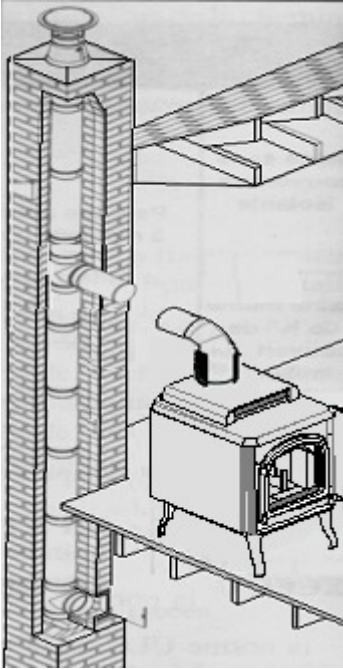

The *Ultimate* must be installed in accordance with the applicable local laws or the CAN/CSA - B365 ULC S635, ULC S640, UL 1777 norms. For the chimney, follow the chimney manufacturer's instructions.

EXTERIOR VERTICAL INSTALLATION

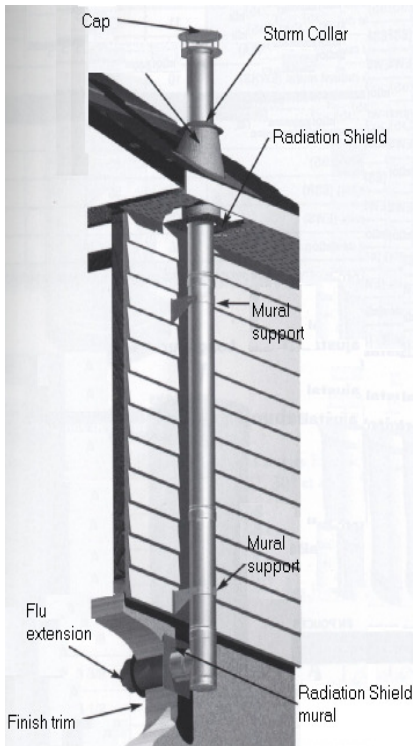

The *Ultimate* must be installed in accordance with the applicable local laws or the CAN/CSA - B365 ULC S635, ULC S640, UL 1777 norms. For the chimney, follow the chimney manufacturer's instructions.

VERTICAL INSTALLATION ON A CATHEDRAL ROOF

The *Ultimate* must be installed in accordance with the applicable local laws or the CAN/CSA - B365 ULC S635, ULC S640, UL 1777 norms. For the chimney, follow the chimney manufacturer's instructions.

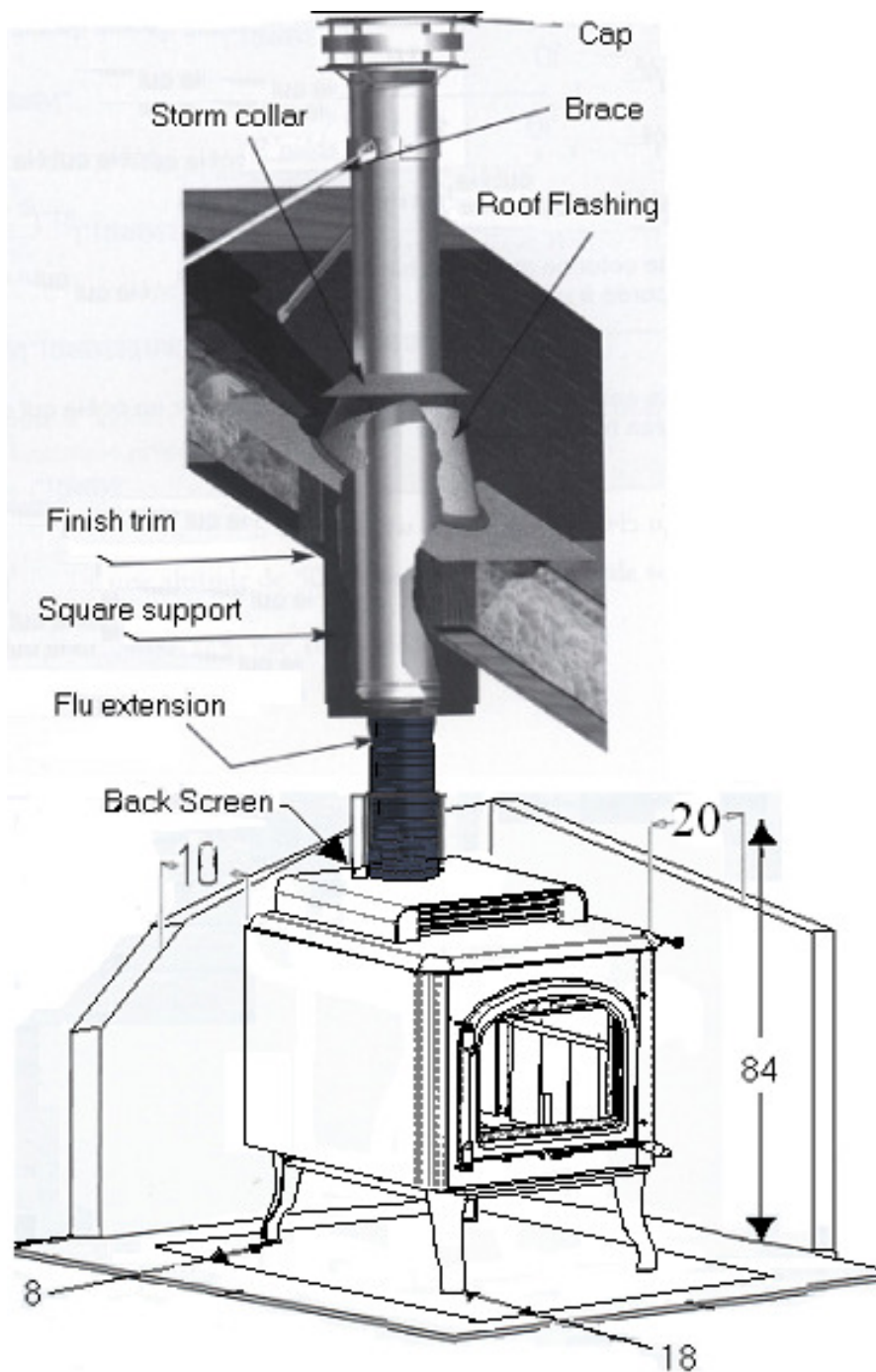

CROSS INSTALLATION

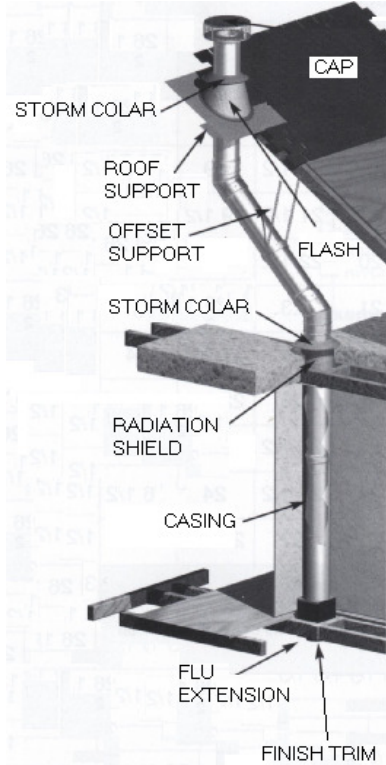

The *Ultimate* must be installed in accordance with the applicable local laws or the CAN/CSA - B365 ULC S635, ULC S640, UL 1777 norms. For the chimney, follow the chimney manufacturer's instructions.

VERTICAL INSTALLATION

The *Ultimate* must be installed in accordance with the applicable local laws or the CAN/CSA - B365 ULC S635, ULC S640, UL 1777 norms. For the chimney, follow the chimney manufacturer's instructions.

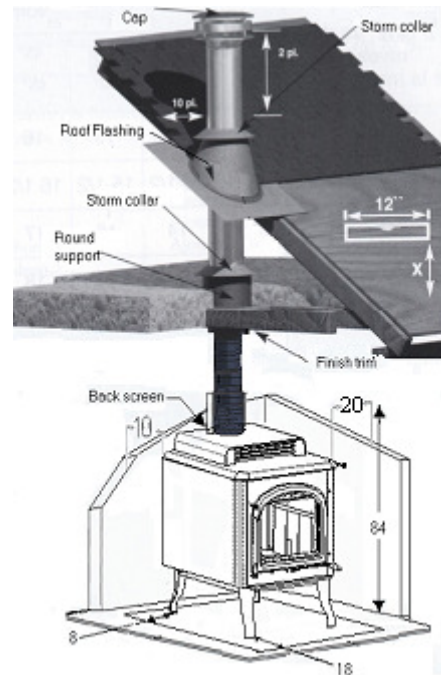

CLEARANCES

Due to its reduced clearances, this appliance occupies a minimum of space in the room where it is installed. No matter where you install it, the *Ultimate* will complete perfectly your decoration by its originality and its heat. With the addition of A heat shield it requires only 10 inches of clearance to the back and 20 inches of the sidewalls, when the installation is made with a simple pipe, the clearances must be 18 inches to the front and the back. In the case of a simple pipe without an heat shield, the clearances are of 18 inches of the smoke pipe.

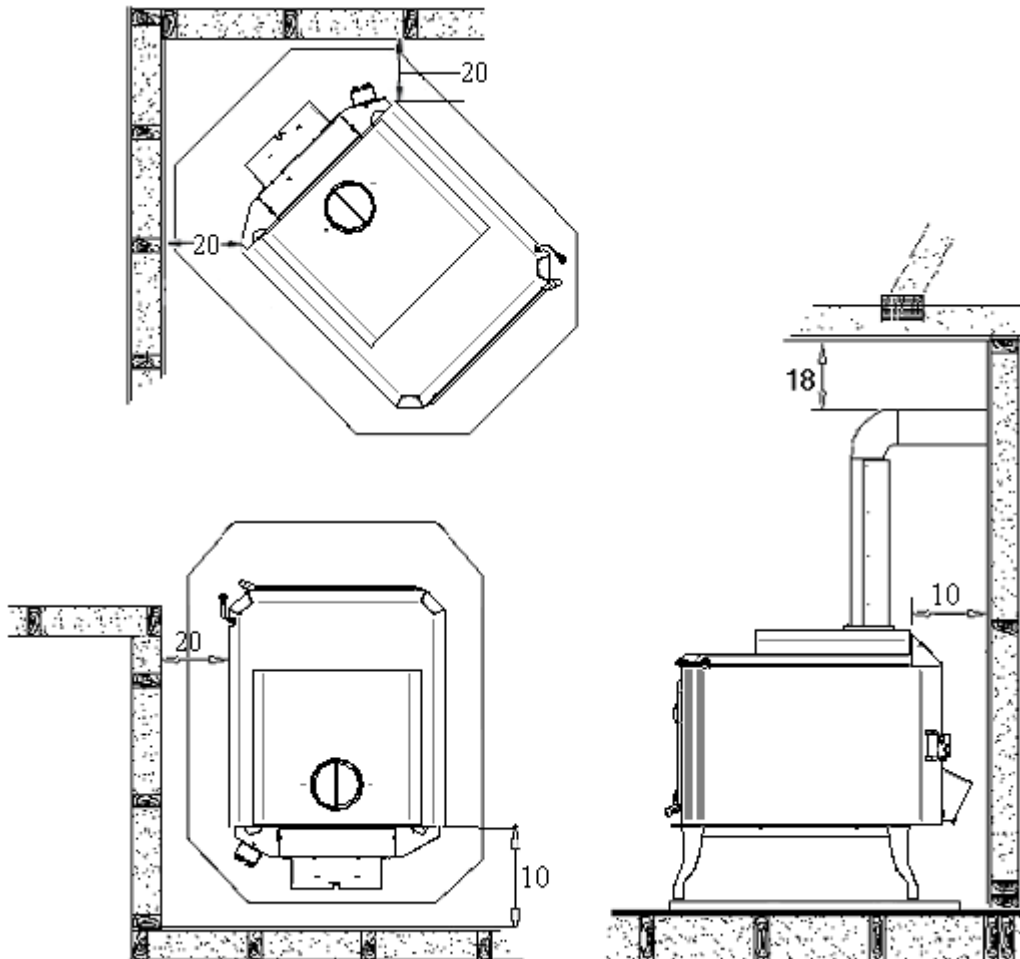

FLOOR PROTECTOR

Your wood stove should be placed on a non-combustible plate under the appliance, which must exceed 18 inches to the front, 8 inches on each side and 8 inches to the back.

***** Only use non-combustible materials.**

Ex : (ceramic, marble, granite)

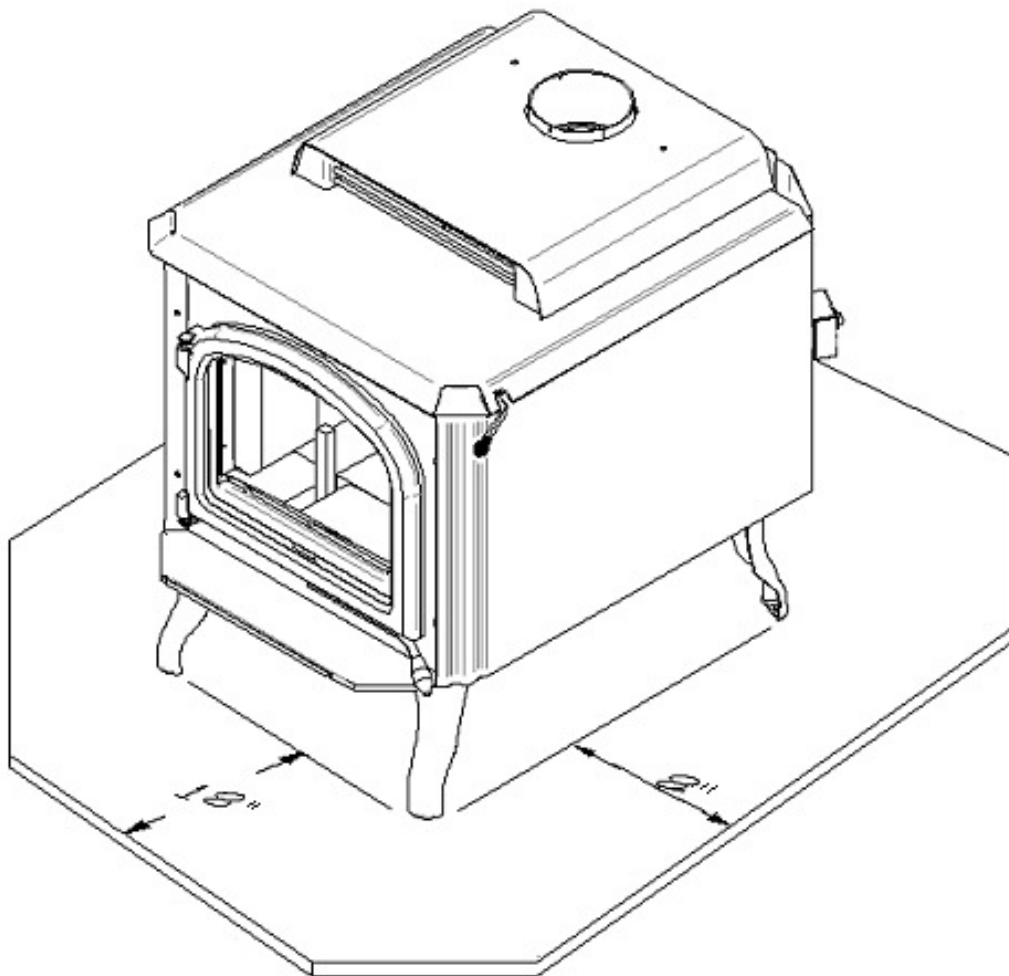

LIGHTING

Now that you have completed the installation of the appliance according to the recommendations, you are ready for the lighting!

1. Before lighting, be sure that the chimney is warm enough by twisting together a few sheets of newspaper in a torch. Light up the paper torch. and hold it as close as possible to the pipe inside the chamber to warm up the chimney.
2. Place papers and kindling in the appliance.
3. When the fire is well lit, gradually add bigger wood logs until an ember bed is formed.
4. You can then control combustion by closing or opening the air intakes (a rod pulled down indicates a closed air intake). The wood will burn more quickly if the air intakes are opened to the maximum and more slowly if they are only slightly open.

Do not charge the appliance beyond the bricks.

FANS AND THERMODISC

The 115 volts fans must be screwed with the grids beneath the air corridor. The thermodisc box must be screwed on the back of the corridor. Connect the thermodisc into the electrical outlet. When the appliance is in function, the heat reaching a temperature of 120°C activates the thermodisc. At this moment, the thermodisc activates the fans for a better distribution of heat in your home. As soon as the heat goes under 120°C, the thermodisc automatically stops the fans.

Be sure that the electric cord of the fan doesn't touch any surface of the appliance in order to avoid an electric shock or a fire hazard.

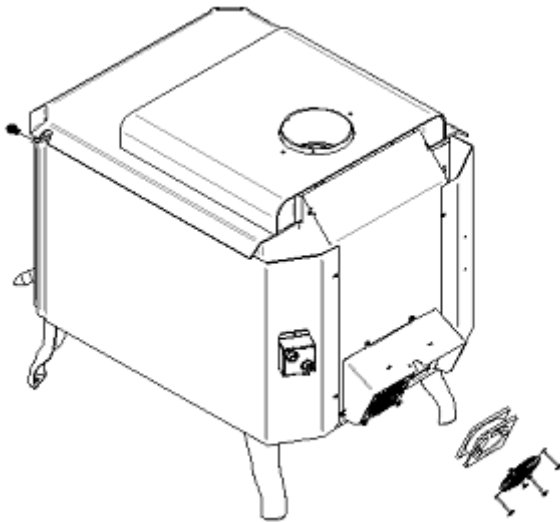
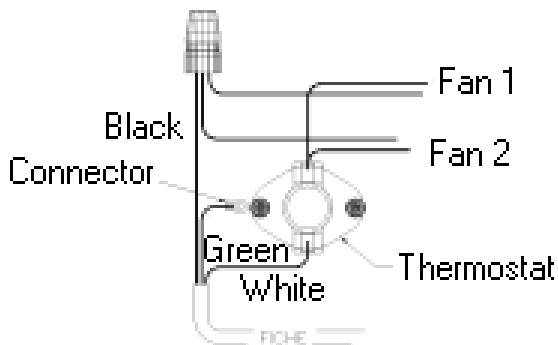

**DO NOT PUT THE ELECTRIC
CORD UNDER THE APPLIANCE.**

PREVENTIVE MEASURES AND MAINTENANCE

1. We recommend to open the air intakes completely and to maintain an intense fire from 10 to 20 minutes per day.
2. Verify the accumulation of creosote every week that you use the appliance until you know at which frequency it must be cleaned (**minimum once per year**).
3. Remove creosote deposit in order to prevent chimney fires.
4. Do not alter or modify the air intakes of the appliance in order to get a stronger fire.
5. To clean the glasses, J.A. Roby Inc. recommends to use products sold for this purpose or an oven cleaner. Avoid cleaning with abrasives or when the glass is hot.
6. Before lighting the first fire, clean the gold plated surfaces using a very soft rag moistened with water. Do not use a paper towel to clean gildings. If they are not erased before the first fire, fingerprints and other marks could stain these surfaces permanently.

GLASS REPLACEMENT:

Remove the screws that retain the glasses and if need be, the fragments of glasses. Check if the seal cords are damaged.

If so, replace them by a ½ inch ceramics cord and replace the broken glasses with a VITROCERAMIC glass of 5mm.

Cut the glass edge 3mm smaller on each side, so that the fiberglass cord can be slipped on the edge of the glass at the time of its installation. Secure the glass with the screws.

Contact your retailer to obtain any information you might need for the replacement of the glass.

DO NOT USE SUBSTITUTES.

REPLACEMENT PARTS LIST

- BRICKS
- WOOL
- PLATES USED TO RETAIN WOOL
- PIPES
- GLASS
- BRICKS SUPPORTS
- DOOR HANDLE
- FANS
- CORDS

*** TO ORDER PARTS, PLEASE CONTACT YOUR AUTHORIZED RETAILER.**

INSTALLATION OF THE FIREBRICKS

1. Before you begin, please take note that the purpose for the screws is to secure the bricks inside the stove.
2. First, install the bricks C(7), F(2), E(5) at the bottom of the stove and C(1) & D(1) on the inclined part near the door.
3. Second, install the bricks to the bottom of the back wall 4 (C), 1 (A) pre-screw the brick supports and screws add C(2) and E(1), when all bricks and supports are installed you can then tighten the screws.
4. Third, install C(12) B(2) A(2) E (2) bricks on the side wall.
5. To install the last top bricks, the rock wool and the retaining plate, follow the last step before lighting the stove.
 - Add the 4 bricks on the pipes. Then add the rock wool and the 2 retaining plates on the bricks. To finish the installation, put the last 3 bricks between the first and the second pipe and put it on the pipes.

BRICKS:	Qty
A 2 ¼" X 9" :	3
B 5" X 9" with 1" angle:	2
C 4 ½" X 9" :	27
D 6 ½ X 4 ½" :	1
E 4 ½" 4 ½" :	8
F 4 ½" X 2 ¼" :	2
G brick support:	3
H screws for support :	3

*****Please take note that that step 1 to step 3 is already done at the factory*****

Figure 1 . 0

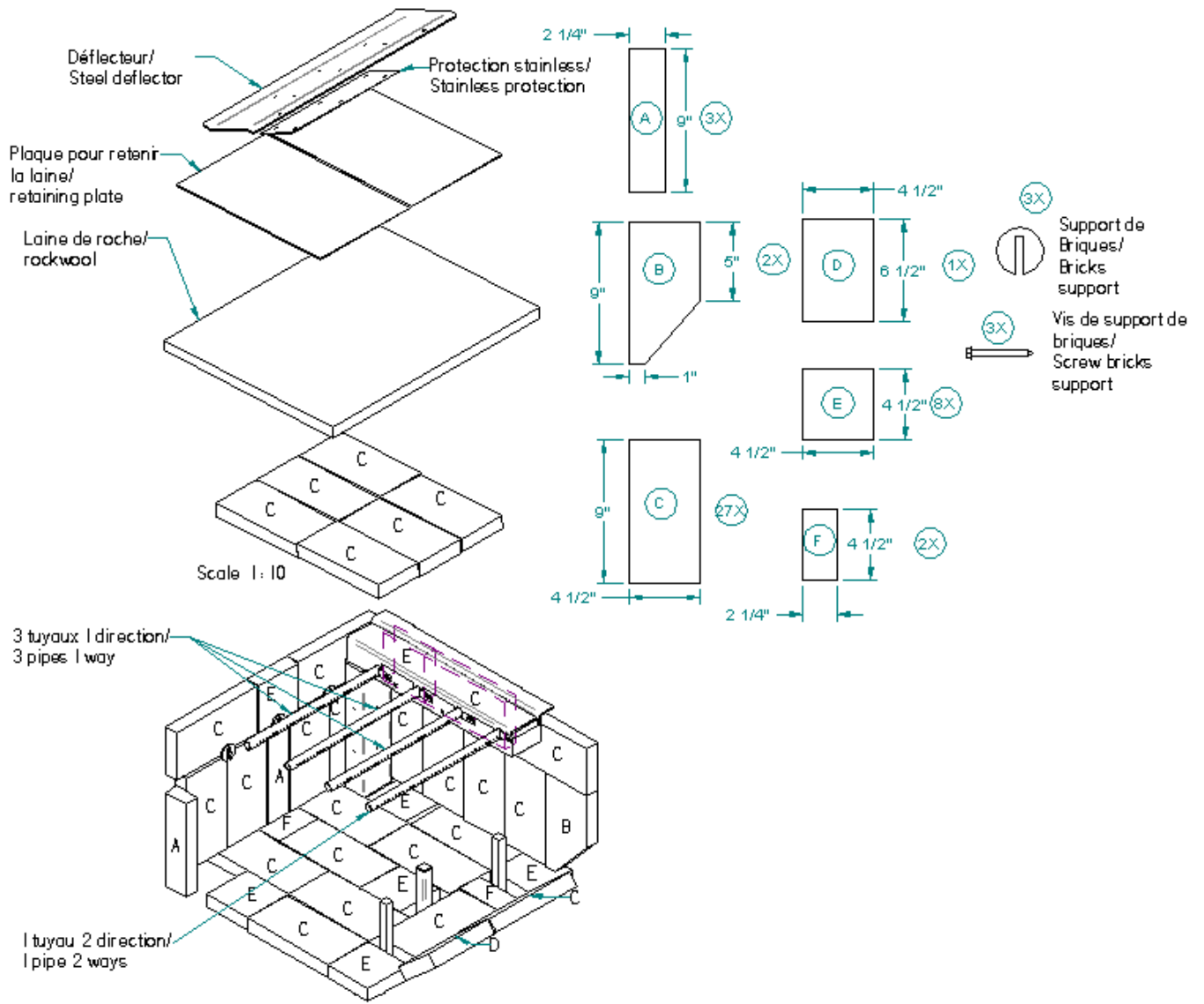

3 tuyaux 1 direction/
3 pipes 1 way

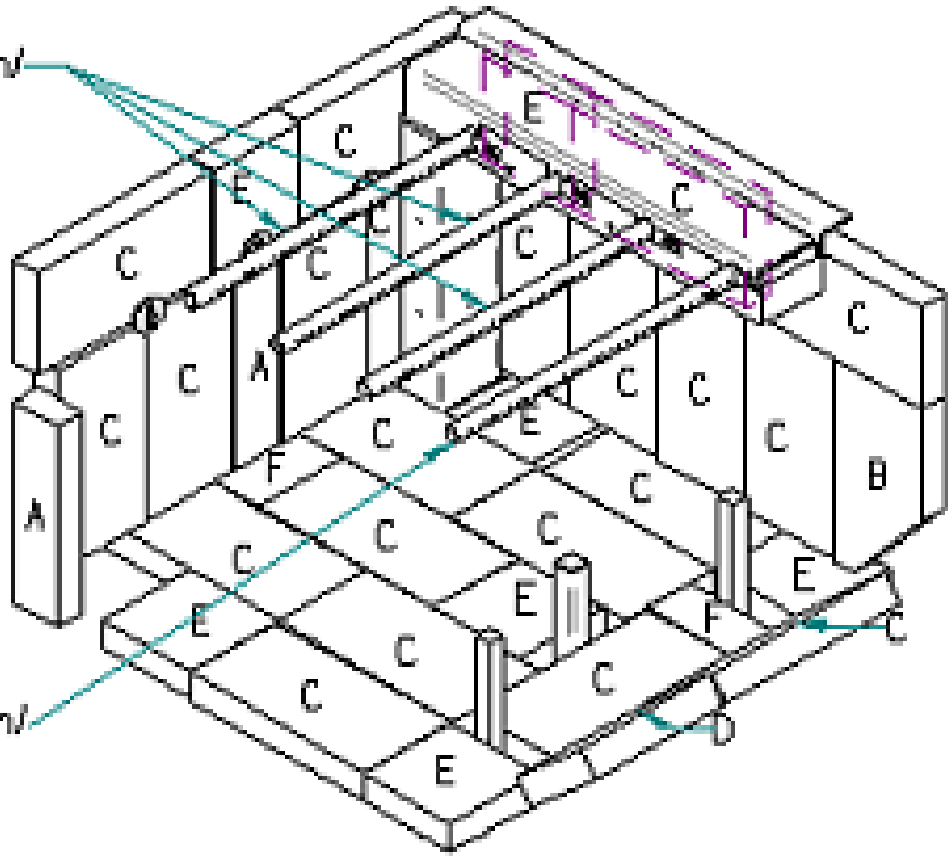

1 tuyau 2 direction/
1 pipe 2 ways



LIMITED LIFE WARRANTY

J.A. ROBY INC. warrants for life (following conditions written in the present manual) its high quality appliances against all manufacturing defectiveness. This warranty is only valid for the first buyer of the appliance with a purchase proof and the serial number of the appliance.

This warranty is valid only for a normal residential utilisation. All damages caused by a misuse, a wrong installation, a wrong maintenance, a negligence or an accident during transportation are not covered by this warranty.

This warranty does not cover scratches, corrosion or discoloration caused by excessive heat, abrasives and chemical cleaners. All defectiveness or damage caused by the use of parts other than the manufacturer's original parts will automatically cancel this warranty.

This warranty is subject to the following exceptions: glass, paint, firebricks, door's plating, decorations, ceramic cord and installation. The fans and electrical parts are covered by a 90 days warranty (from invoice date).

The **1st year**, J.A. Roby Inc. engages to undertake the necessary repairs without additional charges. The appliance must be sent to our manufacture, located at 490, rue de l'Argon, Québec (Québec) G2N 2C9. The owner must prepay transportation charges. **J.A. Roby inc. will NOT accept any transportation charges.**

The 2nd year, J.A. ROBY Inc. assume **50%** of repairs according to the above conditions.

The 3rd year, J.A. ROBY Inc. assume **45%** of repairs according to the above conditions.

The 4th year, J.A.ROBY Inc. assume **40%** of repairs according to the above conditions.

Subsequent years, J.A.ROBY Inc. assume **30%** of repairs according to the above conditions.

You MUST return this card in order to register your appliance for the Warranty.

If your appliance has defectiveness, contact immediately your J.A. Roby Inc. distributor whom will guide you.

Before sending a product or a part at our manufacture, you must receive an authorization number from your sale representative or your J.A. Roby distributor. All merchandise sent without authorization will not be accepted and will be returned to the shipper.

WARRANTY CARD

APPLIANCE MODEL: _____

DATE OF PURCHASE: _____

STORE: _____

INSTALLATION DATE: _____ SERIAL #: _____

NAME: _____

ADDRESS: _____

PROVINCE: _____ POSTAL CODE: _____

INSTALLED BY: _____

BUYER'S SIGNATURE: _____