

MODELS QTR050C, QTRE070C & QTRE080C VENTILATION FANS

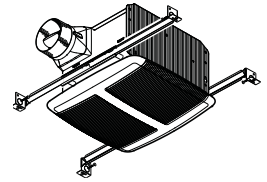

Ultra-quiet, high performance bath fan with a modern-styled grille.

FEATURES

BLOWER:

- Plug-in, permanently lubricated motor - engineered for continuous operation
- Dynamically balanced centrifugal blower wheel for quiet, efficient performance
- Low RPM for quiet operation
- Resilient anti-vibration motor mounts

HOUSING:

- Rugged, 26 gauge, galvanized steel construction
- Polymeric, 4" round duct connector with tapered sleeve and no metallic clatter
- 7-5/8" height allows for 2" x 8" (nominal) joist installations
- Sturdy, easy, four-point mounting directly to joist
- Includes unique spacers (patent pending) for mounting to engineered "I" joists
- Includes hanger bars to position housing anywhere between 16" to 24" on-center joists
- Two sets of mounting holes for hanger bars allow flush installation with bottom or top of drywall

GRILLE:

- Polymeric construction
- Innovative design - the result of extensive research with designers and consumers

BUILDER PACKS:

- Broan Model QTR050C
 - Includes blower and grille only (packed 4 per carton)
- Rough-in housing required - order Broan Model HQTXR000C (4 housings per carton)
 - Includes hanger bars to position housing anywhere between 16" to 24" on-center joists (4 sets of hangers per carton)
 - Two sets of mounting holes for hanger bars allow flush installation with bottom or top of drywall

UL listed for use over bathtubs and showers when connected to a GFCI protected branch circuit (ceiling mount only).

3-Year Warranty



HVI-2100 CERTIFIED RATINGS comply with new testing technologies and procedures prescribed by the Home Ventilating Institute, for off-the-shelf products, as they are available to consumers. Product performance is rated at 0.1 in. static pressure, based on tests conducted in AMCA's state-of-the-art test laboratory. Sones are a measure of humanly-perceived loudness, based on laboratory measurements.

TYPICAL SPECIFICATION

Ceiling Ventilator shall be Broan Model QTR050C (QTRE070C) (QTRE080C).

Ceiling ventilator shall have corrosion resistant galvanized steel housing with four-point mounting capability. It shall be ducted to a roof or wall cap using 4" round ductwork.

Blower assembly shall be removable, have a centrifugal-type blower wheel and a permanently lubricated motor designed for continuous operation and mounted with resilient anti-vibration mounts.

Non-metallic damper/duct connector shall be included.

Air delivery shall be no less than 50 (70) (80) CFM and sound level no greater than 0.4 (1.3) (1.3) sones. All air and sound ratings shall be certified by HVI.

Ceiling ventilator shall be Energy Star® qualified and have an energy efficient permanent split capacitor motor (Models QTRE070C & QTRE080C only).

Ceiling Ventilator shall be UL Listed for use over bathtubs and showers when connected to a GFCI protected branch circuit.

SPECIFICATIONS

Model	Volts	Amps	Sones @0.1" P _s	CFM @0.1" P _s	Shipping Weight
QTR050C	120	0.3	0.4	50	7.8 lb
QTRE070C	120	0.4	0.8	70	11.8 lb
QTRE080C	120	0.4	0.8	80	11.8 lb

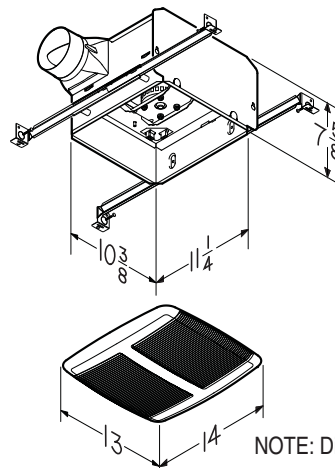

Models
QTRE070C &
QTRE080C only

NOTE: Dimensions are in inches.

Broan-NuTone Canada, Mississauga, Ontario www.broan.ca 877-896-1119

REFERENCE	QTY.	REMARKS	Project
			Location
			Architect
			Engineer
			Contractor
			Submitted by
			Date