

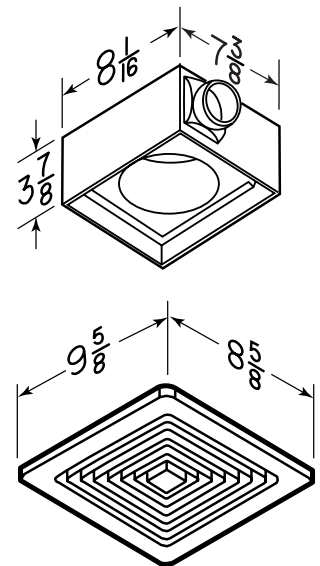

Economy Fans

A quality fan for an incredible value

- Permanently lubricated motor, requires no maintenance
- cUL and UL listed for use over bathtubs and showers (when connected to a GFCI protected branch circuit)
- Housing Dimension: 8-1/16" x 7-3/8" x 3-7/8"
- Low-profile, washable, white plastic grille: 9-5/8" x 8-5/8"
- Rugged steel housing with double strength steel mounting flanges with key hole slots for fast installation
- 3" round duct connector
- Compact housing fits between joists or studs allowing for ceiling or wall installation
- Fits 2" x 4", 2" x 6" and 2" x 8" constructions
- Dynamically balanced impeller blower
- Torsion spring grille mounting means no tools are required to install grille
- Available in single and project packs for builder convenience



SPECIFICATIONS

MODEL	CFM AT 0.1" SP*	L/s** AT 0.1" SP	SONES AT 0.1" SP	POWER RATING	AMPS	SHIPPING WEIGHT (POUNDS)	PROJECT PACK (QTY. 6)	HOUSING PACK (QTY. 6)
EC50	50	23.6	3.0	120/60	1.1	3.6	ECF50	ECH600
EC70	70	33.0	5.5	120/60	1.5	4.1	ECF70	ECH600

* Static pressure

** Litres per second



8725 08